

◆ MATERIAL: SUS301
◆ UNIT: mm

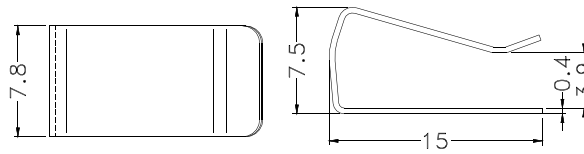

PART NO	PACKAGE
TRMC-1	1000

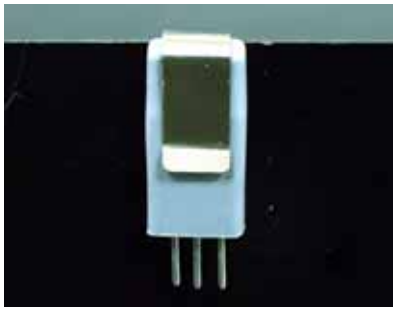
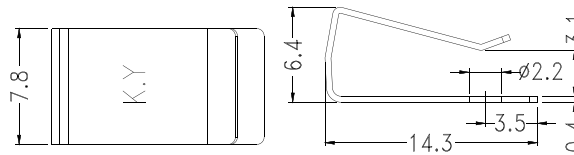
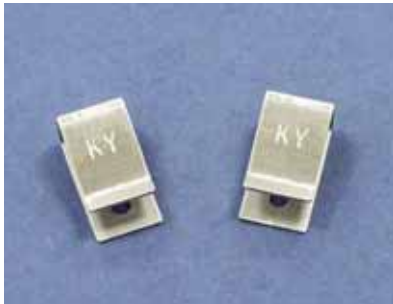

PART NO	PACKAGE
TRMC-2	1000

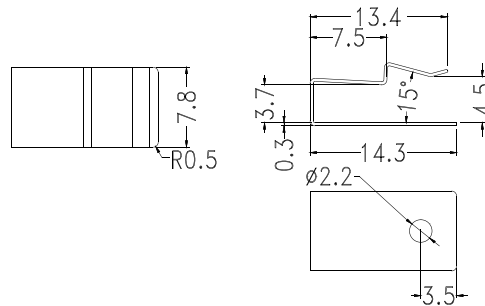
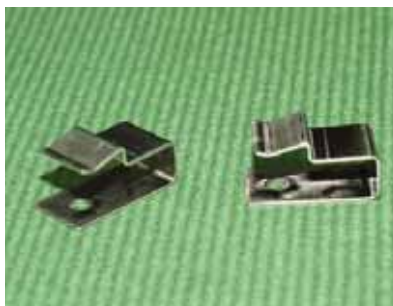

PART NO	PACKAGE
TRMC-5	1000

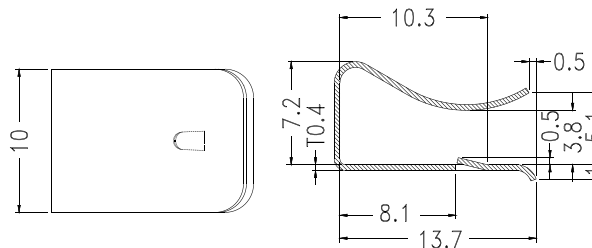

PART NO	PACKAGE
TRMC-6	1000

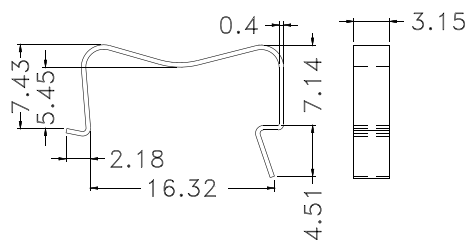

PART NO	PACKAGE
TRMC-8	1000

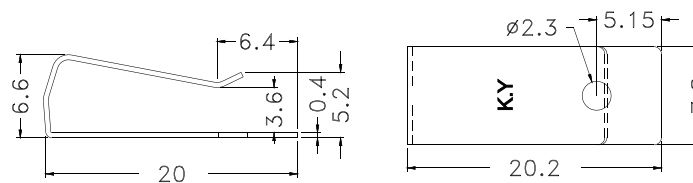

PART NO	PACKAGE
TRMC-9	1000

Electronic Component - CLAMP

Hankook Fastener

- ◆ MATERIAL: TIN PLATED SPCC
- ◆ UNIT:mm

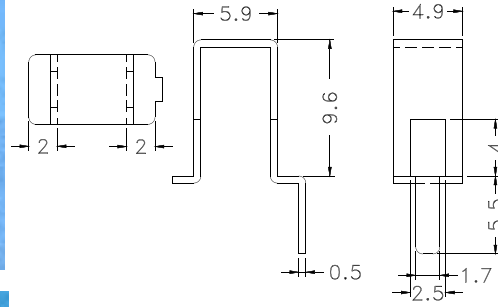
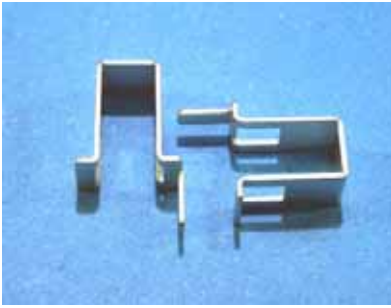

PART NO	PACKAGE
TRMC-10	1000

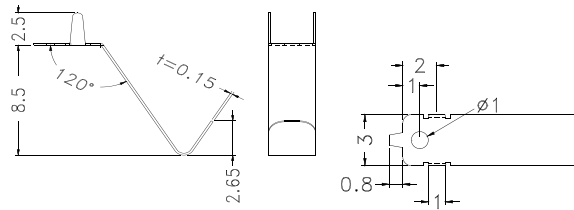

PART NO	PACKAGE
TRMC-11	1000

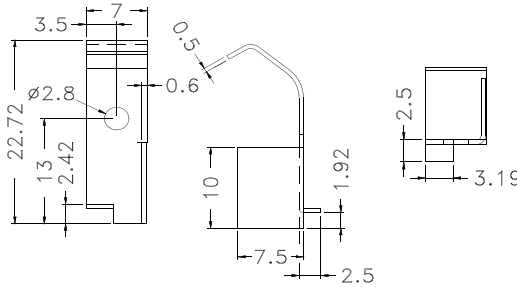

PART NO	PACKAGE
TRMC-12	1000

POWER TRANSISTOR CLAMP DEPRESSOR

- ◆ MATERIAL: STAINLESS-430
- ◆ UNIT:mm

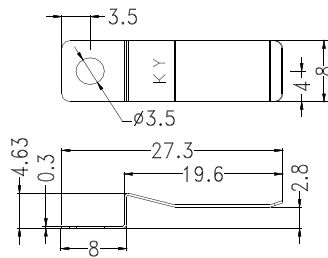

PART NO	PACKAGE
TRK-6	250

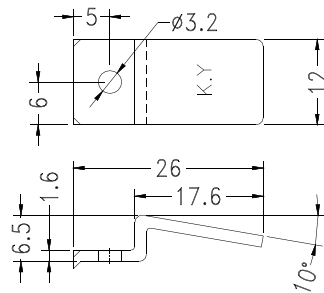
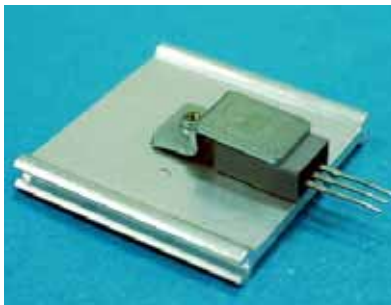

- ◆ MATERIAL: ZINC PLATED STEEL
- ◆ UNIT:mm

PART NO	PACKAGE
TRK-1	250

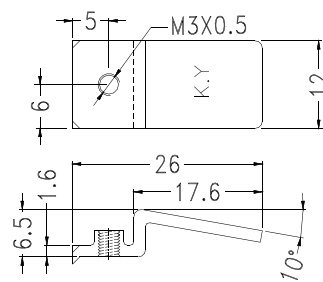

- ◆ MATERIAL: ZINC PLATED STEEL
- ◆ UNIT:mm

PART NO	PACKAGE
TRK-2	250

POWER TRANSISTOR CLAMP DEPRESSOR

Hankook Fastener

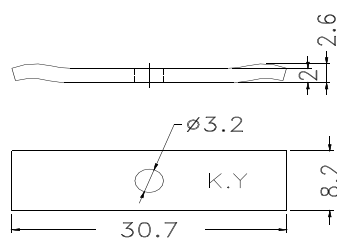
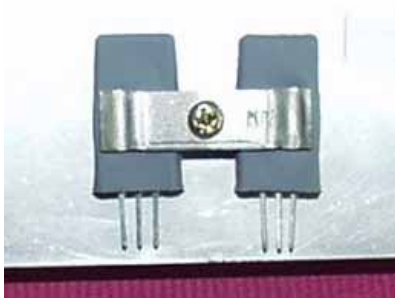

◆ MATERIAL: STEEL
◆ UNIT: mm

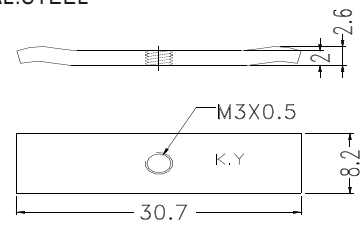

PART NO	PACKAGE
TRK-8	1000

PART NO	PACKAGE
TRK-9	1000

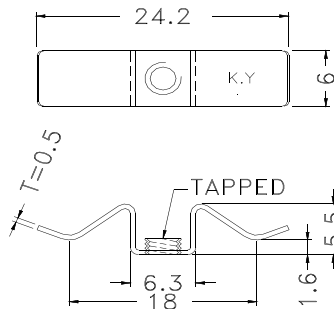

PART NO	TAPPED	PACKAGE
TRK-10	M3X0.5	1000
TRK-10(M4)	M4X0.8	
★TRK-10(632)	6-32 UNC	



◆ MATERIAL: ZINC PLATED SPCC
◆ UNIT: mm

PART NO	PACKAGE
TRK-11	1000

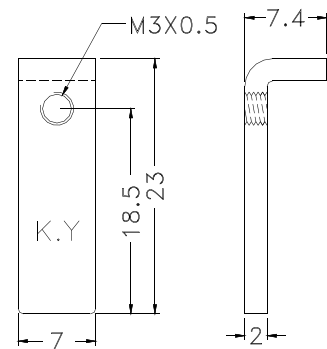

PLASTIC GEAR

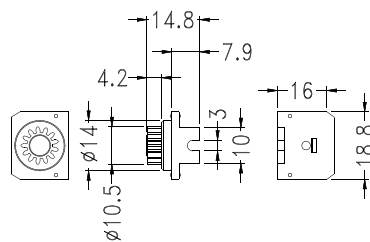

MODULE	0.7
PITCH CIRCLE DIAMETER	φ 9.1
TOOTH NUMBER	13
PRESSURE ANGLE	20°

PART NO	PACKAGE
DP002A	500

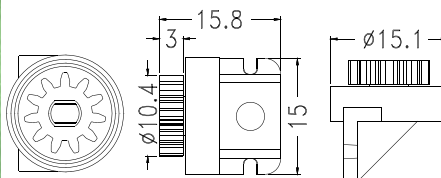

MODULE	0.8
PITCH CIRCLE DIAMETER	φ 8.8
TOOTH NUMBER	11
PRESSURE ANGLE	20°

PART NO	PACKAGE
DP003A	500

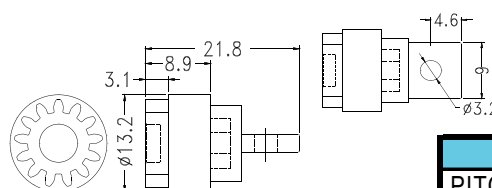

PART NO	PACKAGE
DP004A	500

MODULE	0.8
PITCH CIRCLE DIAMETER	φ 10.4
TOOTH NUMBER	13
PRESSURE ANGLE	20°